

Operating and Programming Manual
Version 1.0

XT-100

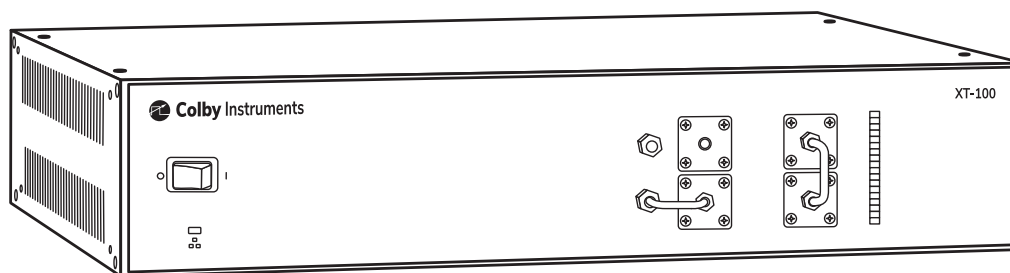

Certification and Warranty

Certification

Colby Instruments certifies that the XT-100 programmable delay line instrument meets all published specifications at the time the instrument is shipped from the manufacturer. SPECIFICATIONS ARE SUBJECT TO CHANGE WITHOUT NOTIFICATION.

Warranty

The product is warranted against defects in material and workmanship for a period of one year from date of shipment. During the warranty period, Colby Instruments will at its option, either repair or replace the product or item which proves to be defective. Replacement products may be either new or like-new.

EXCESSIVE WEAR OF CONNECTORS, THE TROMBONE UNIT, THE COAXIAL RELAYS, AND OTHER RELAYS CARRYING THE SIGNAL, ARE NOT COVERED BY THE WARRANTY. THE FOREGOING WARRANTY SHALL NOT APPLY TO DEFECTS RESULTING FROM IMPROPER CARE OR USE OF THE INSTRUMENT BY THE BUYER. THIS SHALL APPLY TO ALL COMPONENTS DELIVERED TO THE BUYER.

For warranty service or repair, this product must be returned to Colby Instruments. The Buyer shall prepay all shipping charges for the shipment of item to Colby Instruments. Colby Instruments shall pay the shipping charges to return the product to the Buyer. However, the Buyer shall be responsible for ALL shipping charges, duties and taxes for product returned to Colby Instruments from outside the United States of America.

BUYER MUST OBTAIN A RETURN MATERIAL AUTHORIZATION NUMBER (RMA #) FROM COLBY INSTRUMENTS PRIOR TO THE SHIPMENT OF ANY ITEM TO COLBY INSTRUMENTS. SHIP TO:

Colby Instruments

Attn: RMA # _____

15375 SE 30th Place, Suite 320

Bellevue, Washington 98007

USA

No other warranty is expressed or implied. Colby Instruments specifically disclaims the implied warranties or merchantability and fitness for a particular purpose. The remedies provided herein are the Buyer's sole and exclusive remedies. Colby Instruments shall not be liable for any direct or special, incidental or consequential damages, whether based on contract, tort, or any other legal theory.

XT-100 Technical Specificationsiii
XT-100 Trombone Measurementsiv
S21 Insertion Return Loss Reportiv
XT-100 Hostname and MAC-IDiv
Chapter 1.0	1
Description of the XT-100 programmable delay line instrument	1
1.1 Introduction	1
1.2 Delay Line Structure and Design	1
Chapter 2.0	2
Getting Started	2
2.1 Using the XT-100 for the First Time	2
2.1.1 Connecting cables to the XT-100	2
2.2 Self-Test After Power Up	3
Chapter 3.0	4
Using the Front Panel Connections	4
3.1 Overview of the Front Panel Connections	4
3.2 Trombone Only Model XT-100-625P	4
3.3 Models XT-100-001N thru XT-100-100N	4
Chapter 4.0	5
Connecting to XT-100 to Set Delay	5
4.1 About the default IP address and DHCP	5
4.2 Working with Web Browser UI	5
4.3 About the default Username and Password	5
4.4 About the XT-100 Web Server Control Page	6
4.5 About the XT-100 Web Server Information Page.	7
4.6 About the XT-100 Web Server Configure Page.	8
4.7 Working via Remote Interfaces	9
4.8 Communicating over Ethernet TCP/IP	9
4.9 Default Network Addresses.	9
4.10 Restoring to Factory Default Settings.	9
4.11 About Connecting via Telnet to the XT-100.	10
4.12 Setting the delay over RS-232 Serial Port and PC	10

4.13 Attaching the MT-100A Microterminal to the RS-232 port	11
4.14 Attaching the PC to the RS-232 port	11
4.15 Using HyperTerminal and RS-232 connection	12
Chapter 5.0	13
Programming the XT-100.	13
5.1 About Programming the XT-100	13
5.1.1 Instrument ID.	13
5.1.2 Setting the Delay using del1 or del2 commands	13
5.1.3 Querying the current delay setting	13
5.1.4 Setting the delay using a numeric value only.	13
5.1.5 Determine if the operation has completed	14
5.1.6 Check the error code.	14
5.1.7 Determine the network address and settings	14
5.1.8 About the MODE command and MODE? query.	14
5.1.9 Setting a STEP size and using the INC and DEC commands	14
5.2 About Trombone Calibration	15
5.2.1 Enable Calibration Table.	15
5.2.2 Displaying information about the Calibration Table	15
5.2.3 Setting Calibration Table entries	15
5.2.4 Using the Calibration Table	15
5.3 About Relays in the XT-100	16
5.4 About Trombone Serial or Parallel Operating Mode	16
Chapter 6.0	17
Application Programming Interfaces (API) and Commands	17
6.1 Setting Delay Commands and Queries	19
6.2 System Commands	20
6.3 Calibration Table Commands and Queries	22
6.4 Networking Settings.	24
6.5 Common Commands	26
6.6 Relay commands for Models XT-100-001N thru XT-100-100N	28
Chapter 7.0	29
Instrument Backpanel	29

XT-100 Technical Specifications

Model	XT-100
Serial Number	21090000
Firmware Version	1.00
Channel 1	625.0 ps
Signal Input Range	0 - 18 GHz
Minimum Step Resolution	0.25 ps
Maximum Delay Range	625 ps, 2.50 ns, 5.00 ns, 10.0 ns, 20.0 ns, 50.0 ns, 80.0 ns, 100.0 ns
Nominal Delay	3.30 ns
Accuracy of Delay	+/- 0.12 ps σ = 0.05
S21 Typical Insertion Loss	1.0 dB + 1.0 dB x f[GHz] for 0 to 2.0 GHz 3.0 dB + 0.8 dB x f[GHz - 2.0] for 2 to 4.5 GHz 6.6 dB + 0.8 dB x f[GHz - 4.5] for 4.5 to 18.0 GHz
S11 Typical Return Loss	15 dB to 1 GHz 10 dB to 3 GHz 8 dB to 4.5 GHz
Phase Shift Step Resolution	0.18 ° per 1 GHz
Total Phase Shift at 1 GHz	225°, 900°, 1800°, 3600°, 7200°, 18000°, 28800°, 36000°
Total Phase Shift at 5 GHz	1125°, 4500°, 9000°, 18000°, 36000°, 90000°, 144000°, 180000°
Switching Speed*	250 ms – 6500 ms
External Trigger	no
Ethernet TCP/IP	yes
Serial RS-232	yes
MT-100A	optional
Web Browser UI	yes
Microwave Relays Rated	5m MTBF
Recommended Service Interval	500,000 operations or 1 year
Min. frequency for 360° phase shift coverage	1.6 GHz, 400 MHz, 200 MHz, 100 MHz, 50 MHz, 20 MHz, 12.5 MHz, 10 MHz
Power Handling Capability	10W CW, 50W peak *Operating at sustained high power levels while changing delay settings or “hot switching” will significantly reduce operational lifetime of instrument.
AC Supply	85 to 240 VAC, 50-60 Hz
Operating Temperature	10 to 30 deg. C
Physical Dimensions	12" L x 16 3/4" W x 3 1/2" H (2U)
Weight	4.1 kg (9.0 lbs.) to 5.0 kg (11 lbs.)

*depending on network latency

XT-100 Trombone Measurements

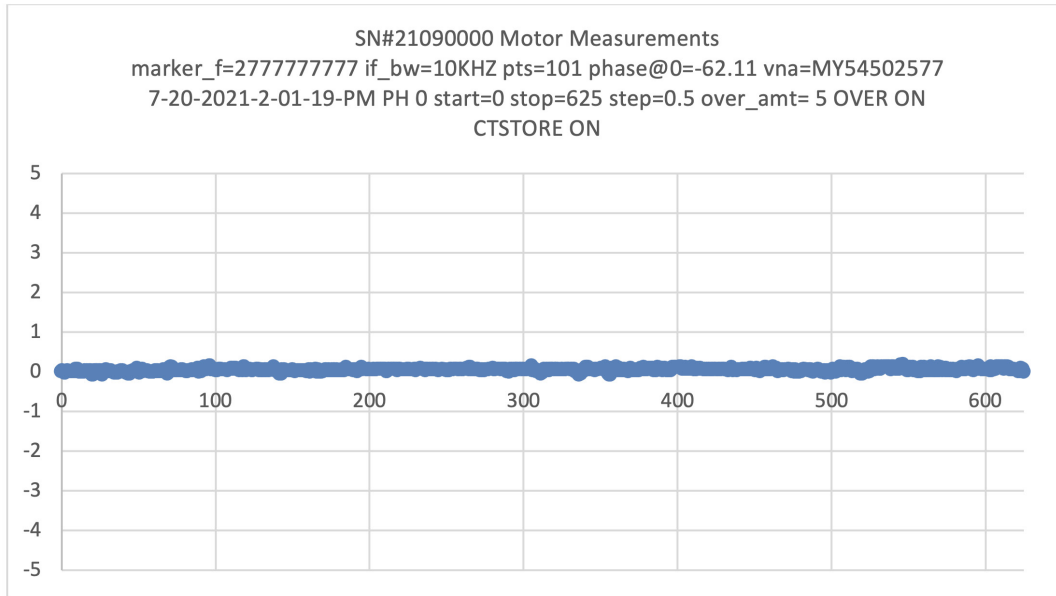

S21 Insertion Return Loss Report

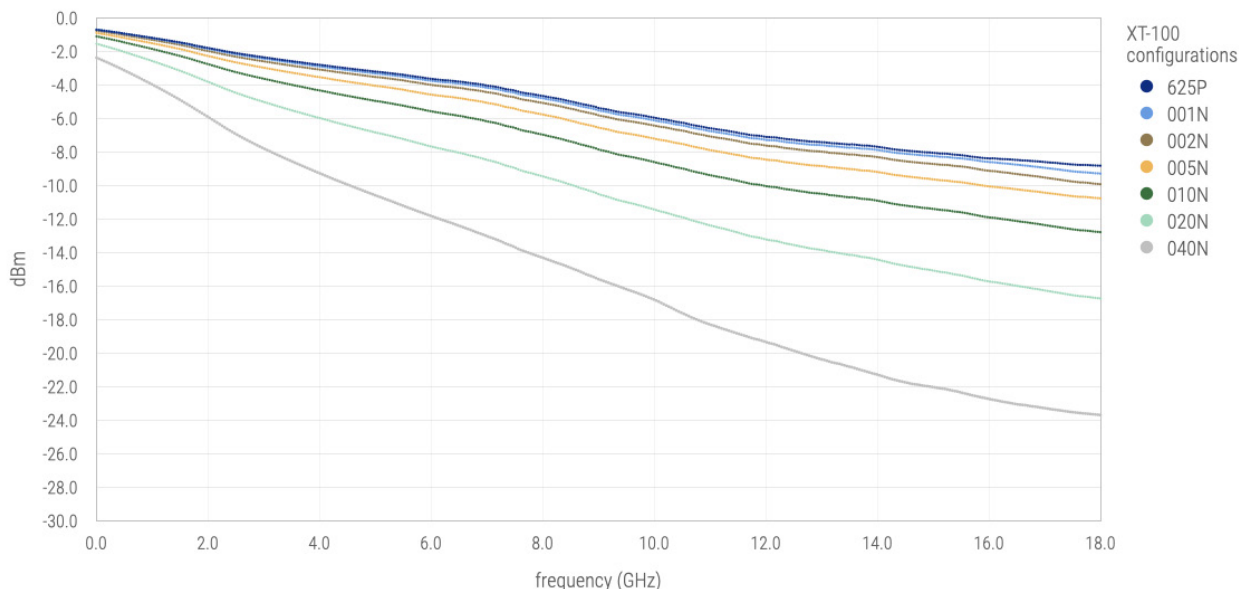

XT-100 Hostname and MAC-ID

Hostname	COLBY_21090000
MAC-ID	00:00:00:00:00:00

Chapter 1.0

Description of the XT-100 programmable delay line instrument

1.1 Introduction

The XT-100 Programmable Delay Line Instrument offers precision programmable delay from 0 to 625.0 picoseconds (ps) range with a step resolution precision to 0.50 ps per step and wideband signal frequency input from DC to 18 GHz.

The XT-100 offers electrical delay (or phase shift) through a patented electromechanical trombone unit by varying the total signal path length. Movement is controlled by a high precision aerospace-grade hybrid stepper motor. Step resolution is to 0.50 ps per step with excellent repeatability.

The XT-100 can be operated locally via Web Browser UI over an Ethernet interface or optionally via MT-100A MicroTerminal over a RS-232 serial port interface. Delay can be set or entered manually or automated via program control. Remote control via Ethernet TCP/IP, RS-232 Serial interface, or Web Browser UI and SCPI command interface is supported.

All signal input and output connections are easily accessible at the front panel and are terminated with female SMA (50 Ω) connectors.

1.2 Delay Line Structure and Design

The XT Series of Programmable Delay Line Instruments is based on an *“electromechanical trombone”* or moveable delay line. A high-frequency signal passing through an extended or contracted trombone experiences correspondingly more or less electrical delay due to the varying total signal path-length. The electrical delay corresponds directly to phase shift when measured in the frequency domain.

A digital hybrid precision stepper motor with a custom precision lead screw is used to position a sled on which one part of the trombone tubing is attached. Precision interfaces are designed to minimize impedance mismatches and a proprietary contact design achieves reliability while minimizing any signal loss or noise.

An embedded CPU microcontroller processes commands from any of the attached hardware interfaces: Ethernet (Web Browser UI, TCP/IP) or RS-232 Serial (optional MT-100A MicroTerminal, or Terminal Emulator program). Commands are processed to move the stepper motor in high-resolution step increments as fine as 0.50 picoseconds(ps) of step resolution (or 0.18 degrees per 1 GHz signal input).

The model XT-100 has one trombone in the base unit. Total delay range can be extended by the in-series addition of one or more delay sections. Each delay section is a pair of aerospace grade microwave relay switches and precision cut semi-rigid coaxial cable in binary step size lengths corresponding to multiples of 625.0 ps. e.g., 625 ps, 1.25 ns, 2.50 ns, etc. Total range of delay is the sum of the entire path length of each of the delay sections. With the combination of binary step sized delay sections and the electromechanical trombone, any 0.50 ps step can be achieved from 0 to total range of the instrument.

Chapter 2.0

Getting Started

2.1 Using the XT-100 for the First Time

After unpacking the instrument, carefully inspect it for any shipping damage. Remove all standard accessories from the shipping carton.

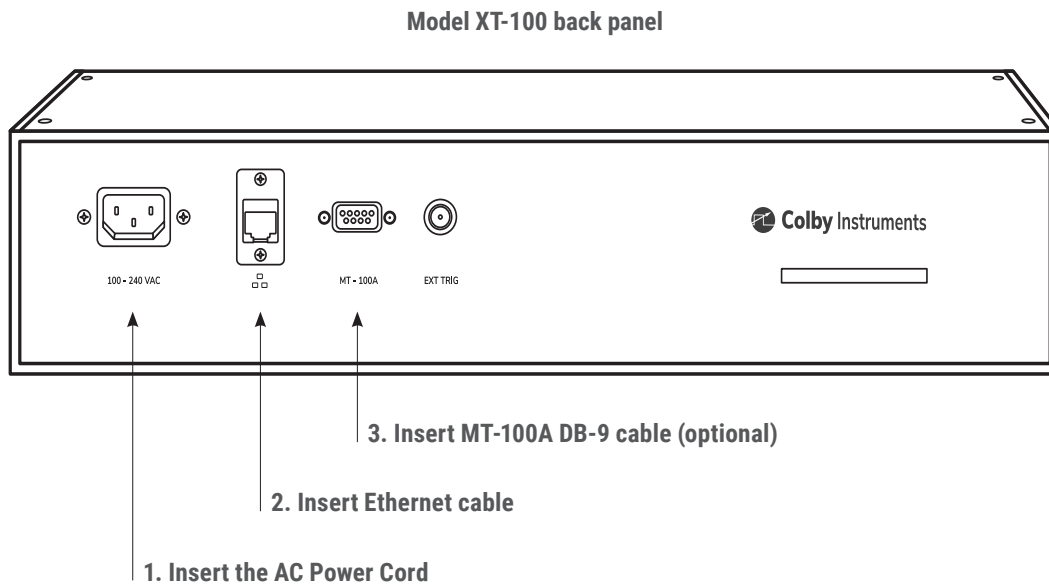

2.1.1 Connecting cables to the XT-100

1. Plug in the XT-100 to a power source by inserting the AC power cord into the 85 to 240 VAC power entry module located on the back panel.
2. If you have an RJ-45 Ethernet cable, connect the cable into the Ethernet Port connector.
3. If you have the (optional) MT-100A MicroTerminal, connect the mated cable to the XT-100 and to the MT-100A MicroTerminal.

2.1.2 Turning power ON to the XT-100

Model XT-100 front panel

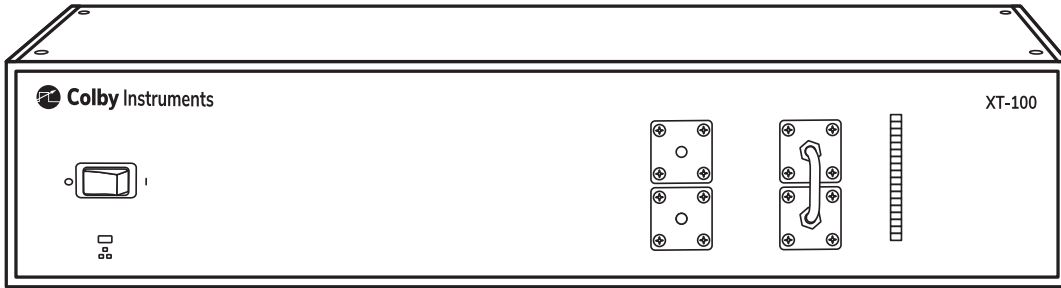

Model XT-100 with extended range delay sections

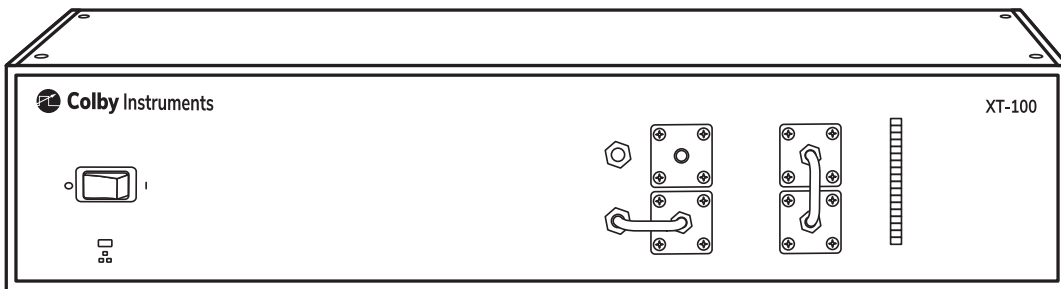

*Push the flat rocker switch on the front panel to turn on the XT-100 System Unit.

2.2 Self-Test After Power Up

The XT-100 utilizes an embedded microprocessor to perform all necessary tasks. Upon power-up, the XT-100 will initialize and perform an initial self-test.

The XT-100 will now check the calibration of the trombone channel by moving the electromechanical trombone delay line towards its maximum setting (maximum delay) until it reaches an infrared light barrier set at a precise position.

A full-speed test is then performed by moving the delay back to 0 relative (minimum delay) and then back to 625.0 ps and re-checking the calibration setting.

If microwave relays are installed, a power cycle to OFF, ON, and then back to the OFF position of all the installed relays will be performed. The delay is reset to its zero delay (0.0 ps) position and the unit is ready to accept commands.

Chapter 3.0

Using the Front Panel Connections

3.1 Overview of the Front Panel Connections

The Trombone **IN** connector begins the signal path and continues through the internal top half of the electromechanical trombone and out across the **vertical jumper** and back through the bottom half of the trombone and exiting at the **OUT** connector.

Model XT-100 single trombone

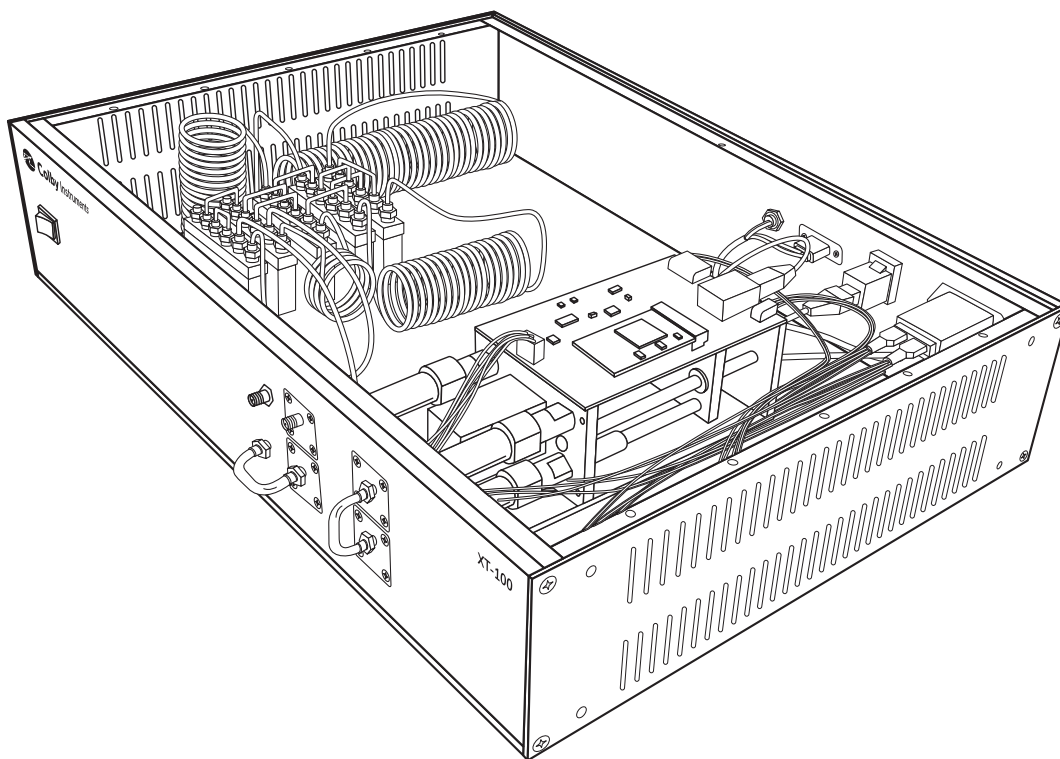

3.2 Trombone Only Model XT-100-625P

The total delay range is from 0 to 625.0 ps offered through both halves of the trombone. The hybrid stepper motor offers 0.50 ps step resolution.

3.3 Models XT-100-001N thru XT-100-100N

Total delay is offered through the electromechanical trombone and delays sections.

Chapter 4.0

Connecting to XT-100 to Set Delay

There are two general methods to connect to the XT-100 to set the delay:

Local

Locally via Web Browser UI via Ethernet interface or via the MT-100A Microterminal

Remote

Remotely via the Ethernet TCP/IP (socket) interface or via the Serial Port RS-232 interface

4.1 About the default IP address and DHCP

The IP address for each instrument is determined by a DHCP Server on your network since DHCP is turned ON by default. The default hostname of your instrument is COLBY_YYMMNNNN where YYMMNNNN is the serial number of your instrument. The instrument serial number, default hostname, and MAC:ID is provided with each instrument produced. This information is provided on the front page of this manual and located on the Backpanel of your instrument.

4.2 Working with Web Browser UI

From your Web Browser enter http://COLBY_YYMMNNNN into the search URL:

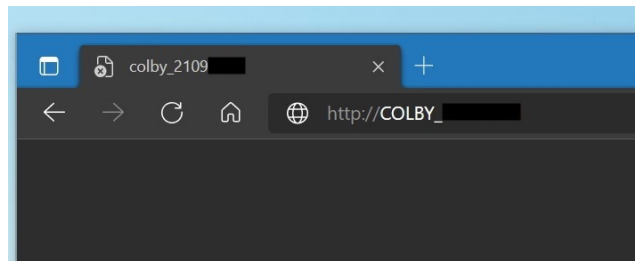

4.3 About the default Username and Password

The default Username is admin and Password is password. You will need to enter these values to sign-in to the XT-100 web server page.

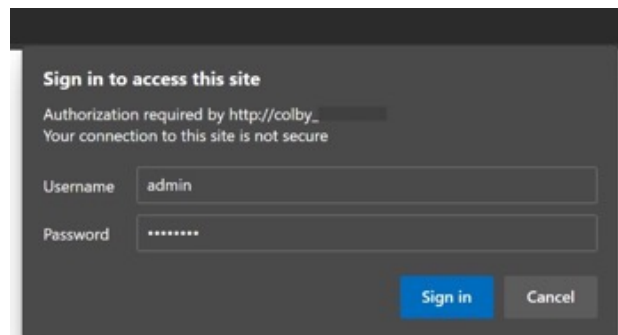

4.4 About the XT-100 Web Server Control Page



[control](#) | [info](#) | [configure](#) | [contact us](#)

Instrument Control XT-100

Channel 1 Delay:	0.00 ps <input type="text"/> ps <input type="button" value="Set Delay"/>
Increment Delay:	Step Size: <input type="text" value="10.0"/> ps <input type="button" value="+"/> <input type="button" value="-"/> Apply to: <input checked="" type="checkbox"/> CH 1
Relays:	16 0000--0000--0000--0000 ¹ 0 Relay Sections
Relay # (1-16):	<input type="text"/> <input type="button" value="Toggle Relay(s)"/>
Commands:	<input type="text" value="Perform Self-Test"/> <input type="button" value="Execute"/>
Message:	

Instrument control is located on this home page. You can set the delay in each channel by entering the desired delay and selecting the Set Delay button.

A step size value can be specified, and a delay channel selected to apply the change to. Select the + or - button to increment or decrement the step size amount of delay.

In the Commands section, a Self-Test or Reset can be performed after selecting the desired item and applying the Execute button.

4.5 About the XT-100 Web Server Information Page



[control](#) | [info](#) | [configure](#) | [contact us](#)

Information

Instrument Model:	XT-100
Manufacturer:	Colby Instruments
Serial Number:	2109
Description:	XT-100 Programmable Delay Line Instrument
# of Channels:	1
Delay Range:	625.00 ps
Step Size:	0.50 ps
Hostname:	<input type="text" value="COLBY_2109"/> <input type="button" value="Set Hostname"/>
MAC Address:	00:00:00:00:00:00
TCP/IP Address:	192.168.8.27
Firmware Version:	V1.00
Message:	

Specific information regarding your instrument is displayed on this page.

The Hostname can be changed or set from this page.

4.6 About the XT-100 Web Server Configure Page



control | info | configure | contact us

Configure XT-100

Description:	<input type="text" value="XT-100 Programmable Delay Line Instrument"/>
Password:	<input type="text" value="password"/>
DHCP:	<input checked="" type="radio"/> on <input type="radio"/> off
IP Address:	<input type="text" value="192.168.8.27"/>
Netmask:	<input type="text" value="255.255.255.0"/>
Gateway:	<input type="text" value="192.168.100.1"/>
Port #:	<input type="text" value="5025"/>
Hostname:	COLBY_2109
Options:	<input checked="" type="checkbox"/> Overshoot <input checked="" type="checkbox"/> Calibration Table
Terminal Mode:	<input checked="" type="radio"/> MT-100A <input type="radio"/> Serial Port
<input type="button" value="Revert"/> <input type="button" value="Defaults"/> <input type="button" value="Save"/>	

The XT-100 instrument IP address (static or dynamic), socket port number, password, network mask, and gateway address can be set here. NOTE: any of these changes may result in an instrument RESET and loss of connection to your existing web browser session.

4.7 Working via Remote Interfaces

There are two different ways to connect remotely:

- Ethernet TCP/IP**
- RS-232 Serial Port**

4.8 Communicating over Ethernet TCP/IP

TCP/IP Socket Protocol sends data packets to individual IP addresses over a unique and pre-specified port. The XT-100 supports fixed (static) and dynamic IP addresses and accepts sockets through a specified port number.

Network Addresses including IP address, Gateway IP, Netmask, DHCP, and Port Number can be specified or changed by sending commands to the XT-100 using the TCP/IP, or RS-232 interfaces.

To change the network addresses using a command interface, see Chapter 6.0 APIs and Commands (NET, NET? and NETM? commands).

4.9 Default Network Addresses

	Value
IP Address	0.0.0.0 (determined by DHCP) default
Gateway Address	192.168.100.1
Netmask	255.255.0.0
DHCP	ON
Port Number	5025
Hostname	COLBY_YYMMXXXX
MAC-ID	XX-XX-XX-XX-XX-XX

These default network addresses are stored internally in non-volatile storage. If you are unable to communicate with the XT-100 over Ethernet after changing a network address and want to restore the default address settings, follow these instructions:

4.10 Restoring to Factory Default Settings

1. Turn off the XT-100
2. Remove the top cover of the instrument.
3. On the Channel 1 Trombone Unit (left most trombone when facing the instrument from the front), locate the center pin hole opening on the Trombone top cover.
4. Insert a needle point into the center hole to depress the Restore To Factory Default Button.
5. While keeping the button depressed, turn ON the XT-100 and keep the button depressed for at least 3 seconds and until the front panel lights flash 3x times ON-OFF,ON-OFF,ON-OFF and then fully OFF to acknowledge reverting to factory default settings.
6. Replace the top cover of the instrument.

4.11 About Connecting via Telnet to the XT-100

You can access the XT-100 via an Ethernet Socket connection using the Telnet (or equivalent) utility. The default port # is 5025. A telnet session can be opened with using the hostname or the IP address of the XT-100.

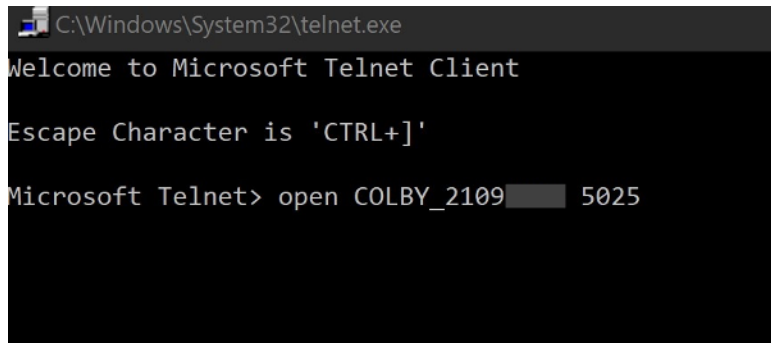

```
C:\Windows\System32\telnet.exe
Welcome to Microsoft Telnet Client
Escape Character is 'CTRL+]'
Microsoft Telnet> open COLBY_2109 5025
```

After a connection is established, enter SCPI commands to communicate to the XT-100. See Chapter 6 Application Programming Interfaces and Commands.

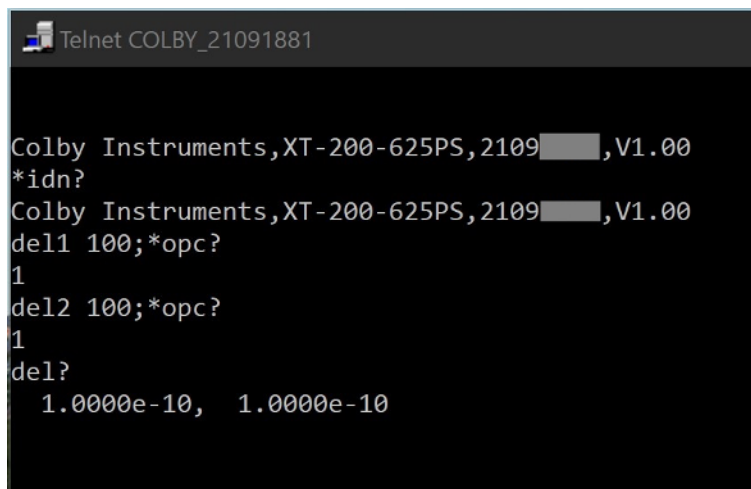

```
Telnet COLBY_21091881
Colby Instruments,XT-200-625PS,2109, V1.00
*idn?
Colby Instruments,XT-200-625PS,2109, V1.00
del1 100;*opc?
1
del2 100;*opc?
1
del?
1.0000e-10, 1.0000e-10
```

4.12 Setting the delay over RS-232 Serial Port and PC

The RS-232 Serial Port is located on the back panel of the XT-100 System Unit and is used to connect to either the MT-100A Microterminal (with the supplied DB-9 male to female cable) or to a PC (with a null model DB-9 female-to-male cable). Port speed is 9600 baud, 8 data bits, and 2 stop bits.

The XT-100 system unit can operate (send command prompts and receive command data) in either Terminal Mode or in MT-100A Mode. You must specify the correct mode prior to attaching either the MT-100A Microterminal or the PC else command prompts will be displayed incorrectly. Default is MT-100A Mode with the Microterminal attached when the XT-100 is first powered-on.

4.13 Attaching the MT-100A Microterminal to the RS-232 port

Ensure the MT-100A Mode is set by sending the command:

command/query	response	description
mode term on		enable MT-100A terminal mode on

to the XT-100. This command can be sent via TCP/IP or via RS-232. If the MT-100A is already connected, you can set the MT-100A Mode **ON** by pressing:

SETUP **3** **ENTER** on the MT-100A.

Note: if the MT-100A Mode is OFF, command prompts from the XT-100 will be displayed incorrectly.

Use the supplied DB-9 mated cable (supplied with MT-100A) to connect the MT-100A Microterminal to the XT-100 System Unit.

4.14 Attaching the PC to the RS-232 port

Ensure the MT-100A Mode is set by sending the command:

command/query	response	description
mode term off		set MT-100A terminal mode off

to the XT-100. This command can be sent via TCP/IP or via RS-232. If the MT-100A is already connected, you can set the MT-100A Mode **OFF** by pressing:

SETUP **3** **ENTER** on the MT-100A.

You must use a "null modem" cable when connecting the PC to the XT-100 System Unit. The null modem cable should have a male DB-9 connector to the XT-100 and a female DB-9 connector to the PC.

RS-232 Port speed is 9600 baud, 8 data bits, and 2 stop bits.

4.15 Using HyperTerminal and RS-232 connection

From Windows Desktop, click on the Windows Start button, click on All Programs, click on Accessories, click on Communications, and click on HyperTerminal to start the HyperTerminal application.

Click on File, and click on Properties:

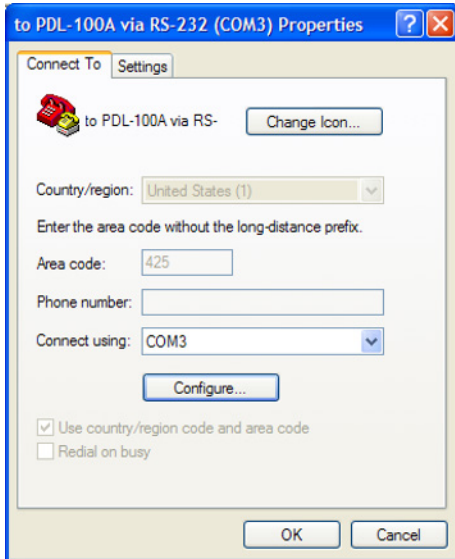

1. Click on the Settings Tab to set the Port Settings.
2. Select 9600 bits per second to connect to the XT-100.
3. Select 2 Stop bits.
4. Select None for Flow Control

Press OK button to continue.

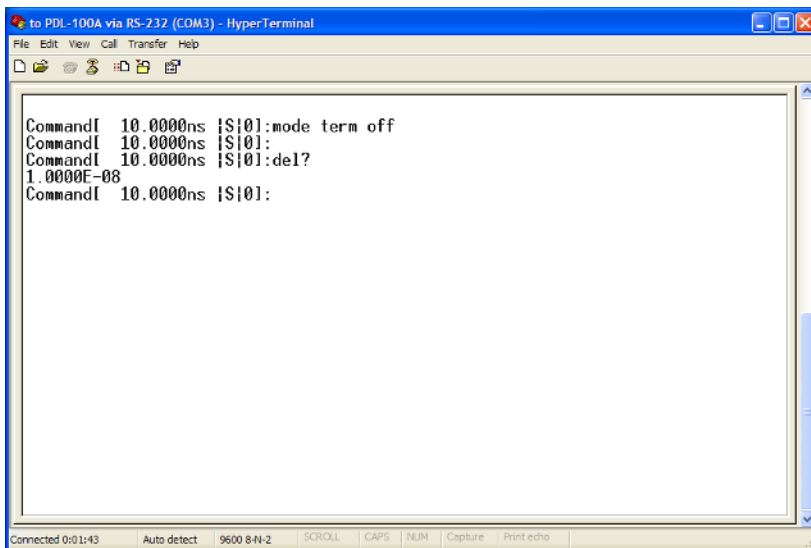

HyperTerminal Session

Chapter 5.0

Programming the XT-100

The XT-100 can be programmed remotely via a set of Application Programming Interface (API) Commands and Queries using a Standard Commands for Programmable Instruments (SCPI) naming convention and syntax.

5.1 About Programming the XT-100

The XT-100 accepts command over the Ethernet or RS-232 Serial port interface. The commands are specified in SCPI format. Commands and Queries are used to automate the operation of the instrument.

5.1.1 Instrument ID

Each XT-100 has a unique Serial # identification.

Use the *IDN? to query the instrument for its identification string.

query	response
*idn?	Colby Instruments,XT-100-625P,21091234,V1.00

5.1.2 Setting the Delay using del1 or del2 commands

The delay in each channel can be specified using the **DEL1** or **DEL2** command.

command	description
del1 123.50	set delay channel 1 to 123.50 ps

5.1.3 Querying the current delay setting

To query the current delay in either Channel 1 or Channel 2:

query	response	description
del1?	1.000000e-10	delay setting

5.1.4 Setting the delay using a numeric value only

The delay setting can be specified with a numeric value only for the current active channel (Channel 1 or Channel 2). Use the MODE command to set the current active channel.

command	response	description
10.0		set delay in current active channel to 10.0 ps
123.50 ps		set delay in current active channel to 123.50 ps

5.1.5 Determine if the operation has completed

After commanding the instrument to set a delay, e.g., sending a del1 or del2 command, use the *OPC? query to determine when the operation has completed. A return value of "1" signifies the new delay setting has taken effect and the trombone has completed movement.

command	response	description
del1 312.50 ps		set delay to 312.50 ps
*opc?	1	operation completed

5.1.6 Check the error code

After sending any command, use the *ERR? or the ERR? query to determine the error code if any.

command	response	description
del1 312.50 ps		set delay to 312.50 ps
*err?	0	no error

5.1.7 Determine the network address and settings

Use the NET? query to determine what the IP address, gateway address, DHCP status, and network settings.

command	response
net?	IP=192.168.8.27,NM=255.255.0.0,GW=192.168.100.1,PORT=5025, DHCP=ON,AD=ON

5.1.8 About the MODE command and MODE? query

The MODE command sets the trombone operating mode to Serial or Parallel mode. Serial mode (default) will round down all delay settings entered to nearest 0.50 step and is used when operating both halves of the trombone when connected. Parallel mode will round down to 0.25 step and is used when only the top or bottom half of the trombone is used.

command/query	response	description
mode 625ps		set to Serial mode
mode?	625 ps	
mode par		set to Parallel mode
mode?	312.50 ps	

5.1.9 Setting a STEP size and using the INC and DEC commands

Delay settings in each channel can be incremented or decremented by a pre-determined step size amount. Use the STEP command to set the step size amount and the INC (increment) or DEC (decrement) command to set the new delay setting.

command/query	response	description
step 25 ps		set step size
step?	2.5000e-11	query the step size
del?	1.000000e-10	
inc		increment
*opc?	1	operation complete
del?	1.250000e-10	
dec		decrement

5.2 About Trombone Calibration

The electromechanical trombone offers a range of delay from 0 to 625.0 ps with a step resolution to 0.50 ps per step. For each of the 1251 delay settings from 0 to 625.0 ps at 0.50 ps steps, a calibration compensation table entry is created at time of instrument manufacture and stored into non-volatile memory. When enabled, every delay setting will apply the calibration compensation to the motor movement position commands to ensure positional accuracy is applied. The CTSTORE command is used to enable (on) or disable (off) the use of this calibration table. The CTSTOREM command is used to download the calibration table to the instrument. In normal usage, there is no need to download or update the calibration table. There are no end user calibration measurements or compensations that can be applied. The CTSTORE? query will return the current status or information about specific entries in the calibration table or information regarding this table.

5.2.1 Enable Calibration Table

command/query	response	description
del1 312.50 ps		set delay channel 1 to 312.50 ps
*err?	0	no error

5.2.2 Displaying information about the Calibration Table

command/query	response
ctstore? info	DATE=12/20/2020_9:55:11_AM,SN=1711XXXX,VNA=E8362C-MY43021160,MARKER_F=0277777777

5.2.3 Setting Calibration Table entries

command/query	response	description
ctstore 100 020		set entry # 100 to +020 fs
ctstore?	0	query calibration table entry at index 100
ctstorem 100 1,2,3		store multiple calibration entries starting at index 100

5.2.4 Using the Calibration Table

command/query	response	description
ctstore on		set to use the calibration table on each delay setting
ctstore?	on	query the status of using calibration table

5.3 About Relays in the XT-100

The XT-100 offers extended delay range via an in-series aerospace-grade microwave relays and precision-cut semi-rigid coaxial cable. Each delay section and relay pair is a binary step sized value of delay with a step size multiple of 625.0 ps.

Relay #	XT-100-001N	XT-100-002N	XT-100-005N	XT-100-010N	XT-100-020N	XT-100-040N	XT-100-080N	XT-100-100N
1	625 ps	625 ps	625 ps	625 ps	625 ps	625 ps	625 ps	625 ps
2		1.25 ns	1.25 ns	1.25 ns	1.25 ns	1.25 ns	1.25 ns	1.25 ns
3			2.50 ns	2.50 ns	2.50 ns	2.50 ns	2.50 ns	2.50 ns
4				5.00 ns	5.00 ns	5.00 ns	5.00 ns	5.00 ns
5					10.00 ns	10.00 ns	10.00 ns	10.00 ns
6						20.00 ns	20.00 ns	20.00 ns
7							40.00 ns	40.00 ns
8								20.00 ns
9-16 n/a								

With the in-series combination of delay sections and trombone, the XT-100 can offer delay within the entire range of the instrument at the step precision to 0.50 ps per step. The XT-100 determines automatically which relays to turn on or off in combination with the trombone position when specifying a delay setting.

Relays can be commanded to turn on or off individually by using the REL command. If relays are not used over a long period of time, they may need to be cycled off-on-off or exercised in-order to overcome any stiction force that may be present from inactivity or storage over a long period of time. Use the RELC to cycle the relays from 1 to 100 cycles.

After specifying a DEL command and delay setting value, the XT-100 will switch the required relays and position the trombone motor. Use the *OPC? query to check when the operation has completed before continuing with additional delay settings or commands.

5.4 About Trombone Serial or Parallel Operating Mode

Internally, the electromechanical trombone consists of two halves (each half in the form of a U-shaped tube) connected by a center moving plate to which a leadscrew and hybrid motor is attached. Both ends of each U tube are accessible at the front panel. A vertical jumper between the top and bottom U tubes is installed at time of production.

Each U tube signal path offers a total delay range from 0 to 312.50 ps. By addition of the front vertical jumper to the connect the top and bottom U tubes, the total range of the trombone is 0 to 625.0 ps. This mode of trombone operation is called Serial mode. The effective minimum resolution step size is to 0.50 ps.

If the vertical jumper is removed, you can operate the trombone in Parallel mode. This mode offers 0 to 312.25 ps of total range delay in either the top or bottom U tube but the step resolution is increased to 0.25 ps per step. There is only one hybrid stepper motor and both U tubes are connected via a center moving plate, therefore each U tube experiences the exact same amount of delay. Parallel mode should only be used when higher step resolution of 0.25 ps is required. Note: delay settings will round down to the nearest 0.25 ps step and there will be "312.50 ps wide gaps" (inability to achieve actual delay setting) across the range.

Use the MODE command to set the Serial (default) or Parallel operating mode for the trombone.

Chapter 6.0

Application Programming Interfaces (API) and Commands

The following commands are specific to the XT-100 instrument:

Setting Delay Commands and Queries	
DEL arg1 [ps ns]	Delay command set delay in active channel
DEL?	Delay query both channels
ERR? or *ERR?	Error query error status code

System Commands	
DEC	Decrement step command
INC	Increment step command
MODE 625 ps	Relay command set
MODE 312.5 ps	Relay query
MODE par 312.5ps	set parallel trombone mode (to 0.25 ps step)
MODE ser 625ps	set serial trombone mode (to 0.50 ps step)
UNITS ns	set units mode to ns for numeric values
UNITS ps	set units mode to ps for numeric values
UNITS?	returns current units mode for numeric values
STEP arg1 [ps ns]	Step command set step size
STEP?	Step query step size

Calibration Table Commands and Queries	
CTSTORE arg1 arg2	Store one entry into calibration table
CTSTORE on off	Use calibration table command
CTSTORE save	Save calibration table to NVRAM
CTSTORE load	Load calibration table to memory
CTSTORE info	Report calibration table information
CTSTORE reset	Reset and clear calibration table
CTSTOREM	Store multiple entries into calibration table
CTSTORE?	Use calibration table query
CTSTORE? arg1	Query individual entries in calibration table

Networking Settings	
NET IP arg1	Set network IP address
NET GW	Set network gateway address
NET NM	Set network netmask
NET PORT	Set network port #
NET DHCP	Set DHCP to dynamic or static
NET AD	Set network autodrop connection
NET HOSTNAME arg1	Set network hostname
NET?	Query network settings
NET? HOSTNAME	Query network hostname
NETM?	Query network MAC-ID

Common Commands	
*CAL?	Calibrate Self-Test and Return Status
*CLS	Clears the instrument settings
*IDN?	Identification String (model and serial number)
*RST	Reset instrument
*TST?	Self-Test Trombone and Return Status
*OPC	Set Operation Complete Bit
*OPC?	Query the Operation Complete Bit

Relay Commands for Models XT-100-001N thru XT-100-100N	
REL arg1 [on off]	Relay command set
REL?	Relay query
RELC arg1	Relay exercise cycles

6.1 Setting Delay Commands and Queries

Common Commands	
DEL arg1 [ps ns]	Delay command set delay in active channel
DEL?	Delay query both channels
ERR? or *ERR?	Error query error status code

DEL arg1	Set Delay (QUERY)						
Description	<p>The del command sets the delay to the value specified in arg1. The desired delay must be within the total delay range of the device.</p> <p>Delay can be specified in either picosecond (ps) or nanosecond (ns) units if the corresponding ps or ns is indicated. Default is picosecond units if not specified. The instrument will round DOWN to the nearest step size resolution if unable to provide exact delay as entered.</p>						
Syntax	<p>DEL arg1 [ps ns]</p> <table border="1"> <tbody> <tr> <td>arg1</td> <td>desired delay setting value</td> </tr> <tr> <td>ps</td> <td>picosecond units</td> </tr> <tr> <td>ns</td> <td>nanosecond units</td> </tr> </tbody> </table> <p>Note: Picoseconds is the default units used if no units are specified in the command line.</p>	arg1	desired delay setting value	ps	picosecond units	ns	nanosecond units
arg1	desired delay setting value						
ps	picosecond units						
ns	nanosecond units						
Example	<p>del 312.50 ps</p> <p>del 100</p>						
Returns	None. Check error code.						

DEL?	Delay Setting? (QUERY)
Description	Returns the current delay settings for Channel 1 and Channel 2
Syntax	<p><x.xxxxeyy><n ></p> <p>(xxxx) is a 4 digit mantissa and (yy) a two digit exponent.</p>
Returns	3.125000e-10

ERR? or *ERR?	Error code query (QUERY)												
Description	Returns the error status												
Returns	<table border="1"> <tbody> <tr> <td>0</td> <td>No Error</td> </tr> <tr> <td>1</td> <td>Invalid Command</td> </tr> <tr> <td>2</td> <td>Invalid Argument</td> </tr> <tr> <td>3</td> <td>No calibration</td> </tr> <tr> <td>4</td> <td>Delay setting limit (out of range)</td> </tr> <tr> <td>5</td> <td>Delay not set</td> </tr> </tbody> </table>	0	No Error	1	Invalid Command	2	Invalid Argument	3	No calibration	4	Delay setting limit (out of range)	5	Delay not set
0	No Error												
1	Invalid Command												
2	Invalid Argument												
3	No calibration												
4	Delay setting limit (out of range)												
5	Delay not set												

6.2 System Commands

System Commands	
DEC	Decrement step command
INC	Increment step command
MODE [del1 del2]	Mode command to set active channel
MODE?	Mode query current active channel
STEP arg1 [ps ns]	Step command set step size
STEP?	Step query step size

DEC	Decrement step (QUERY)
Description	Decrement the delay setting by the step size amount.
Returns	None

INC	Increment step (QUERY)
Description	Increments the current delay setting by the step size amount.
Returns	None. Check error code.

MODE	Set trombone operating mode (COMMAND)	
Description	Sets the current trombone operating mode to Serial or Parallel mode and for for specifying delay setting values for rounding down.	
Syntax	mode [ser 625ps par 312.5ps]	
	mode [term on off]	
	ser 625ps	sets step resolution to 0.50 ps
	par 312.5ps	sets step resolution to 0.25 ps
	term on	set Terminal mode on
	term off	set Terminal mode off
Returns	None. Check error code.	

MODE?	Query trombone operating mode (QUERY)	
Description	Returns the current trombone operating mode for specifying delay setting values for rounding down.	
Returns	ser	round down to 0.50 ps – Serial Mode
	625ps	round down to 0.50 ps – Serial Mode
	par	round down to 0.25 ps – Parallel Mode
	312.5ps	round down to 0.25 ps – Parallel Mode

STEP	STEP step size (QUERY)
Description	Specifies the step size amount when using the INC or DEC command. Use INC (increment) or DEC (decrement) commands to change delay setting by the step size amount.
Syntax	step arg1 [ps ns]
	arg1 delay step size
	ps picoseconds
	ns nanoseconds
Example	step 100 ps
Returns	None. Check error code.

STEP?	Step query (QUERY)
Description	The step? query command is used return the current delay setting step size.
Syntax	<x.xxxx-yy><nl> (xxxx) is a 4 digit mantissa and (yy) a two digit exponent.
Returns	5.0000e-12

UNITS	Sets the default units (COMMAND)
Description	Sets the default units mode when specifying numeric delay setting values only, e.g., "123.50" (without the DEL command) and for display on MT-100A MicroTerminal.
Syntax	units [ns ps]
	ps picoseconds
	ns nanoseconds
Returns	None. Check error code.

UNITS?	MODE active channel query (QUERY)
Description	Returns the current units for specifying values of delay directly
Returns	ps picoseconds
	ns nanoseconds

6.3 Calibration Table Commands and Queries

CTSTORE arg1 arg2	Store one entry into calibration table
CTSTORE on off	Use calibration table command
CTSTORE save	Save calibration table to NVRAM
CTSTORE load	Load calibration table to memory
CTSTORE info	Report calibration table information
CTSTORE reset	Reset and clear calibration table
CTSTOREM	Store multiple entries into calibration table
CTSTORE?	Use calibration table query
CTSTORE? arg1	Query individual entries in calibration table

CTSTORE	Calibration table parameter set (COMMAND)	
Description	Operates on the in-memory calibration table. The in-memory calibration table (when enabled) will apply a calibration position offset to ensure positional accuracy of the stepper motor.	
Syntax	CTSTORE [save load reset on off info [arg1]]	
	save	Stores in-memory calibration table into non-volatile random-access memory (NVRAM).
	load	Load into memory the calibration table from NVRAM.
	reset	Clears all in-memory calibration table entries. Sets "no calibration" text entry into the info setting.
	on	use Calibration table compensation (default)
	off	do not use Calibration table compensation when setting delay settings
	info	set the Calibration table text entry to [arg1]. 128x characters max.
Returns	None	

CTSTORE save	Calibration table save (COMMAND)
Description	Saves calibration table to non-volatile memory
Returns	None

CTSTORE load	Calibration table load (COMMAND)
Description	Load calibration table from non-volatile memory
Returns	None

CTSTORE reset	Calibration table reset (COMMAND)
Description	Clears all in-memory calibration table entries. Sets "no calibration" text entry into the info setting.
Returns	None

CTSTORE on off	Calibration table use (COMMAND)
Description	Calibration table use enable (on) or do not use (off)
Returns	None

CTSTORE info arg1	Calibration table set information (COMMAND)
Description	Sets the calibration table information to arg1. 128x characters max.
Returns	None

CTSTORE?	Calibration table in use query (COMMAND)				
Description	Returns calibration table in use status				
Returns	<table border="1"> <tr> <td>0</td> <td>calibration table not in use</td> </tr> <tr> <td>1</td> <td>calibration table in use</td> </tr> </table>	0	calibration table not in use	1	calibration table in use
0	calibration table not in use				
1	calibration table in use				

CTSTORE? info	Calibration table information (QUERY)
Description	Return the calibration table description information text
Returns	DATE=12/20/2020_9:55:11_AM,SN=1711XXXX,VNA=E8362C-MY43021160,MARKER_F=0277777777

CTSTOREM	Calibration Table Store Multiple (QUERY)
Description	CTSTOREM stores multiple entries into the Calibration Table starting with the first entry at the specified index. The Calibration Table is stored in non-volatile memory.
Syntax	<p>CTSTOREM index [arg1, arg2, arg3, arg4 ... arg20] index is the starting index in the Calibration Table to store the following entries. There are 1251 entries (0 thru 1250) for each 0.5 ps step from the entire range of 0 to 625.0 ps. arg1, arg2, ... table entries ...</p> <p>Note: Each entry in the table is the integer amount of femtoseconds (fs) of calibration compensation required at each step in the entire range of the trombone. Each entry (or compensation amount) is subtracted from the actual performance of the uncalibrated trombone to offer the corrected calibrated position of delay.</p> <p>Maximum of 20 arguments can be specified per line.</p>
Example	CTSTOREM 100 1005, -2002, -0310, 0088 ...
Returns	None

6.4 Networking Settings

NET IP arg1	Set network IP address
NET GW	Set network gateway address
NET NM	Set network netmask
NET PORT	Set network port #
NET DHCP	Set DHCP to dynamic or static
NET AD	Set network autodrop connection
NET HOSTNAME	Set network hostname
NET?	Query network settings
NET? HOSTNAME	Query network hostname
NETM?	Query network MAC-ID

NET	Network Settings (COMMAND)		
Description	The NET command sets the network addresses and other network settings for the instrument. Addresses are stored in non-volatile memory.		
Syntax	NET [IP GW NM PORT DHCP AD] [ON OFF arg1]		
	command	arg1	description
	ip	XXX.YYY.ZZZ.AAA	set ip address
	gw	XXX.YYY.ZZZ.AAA	set gateway address
	nm	XXX.YYY.ZZZ.AAA	set network mask
	port	XXXX	port number
	dhcp	ON OFF	DHCP
	ad	ON OFF	autodrop
Example	net ip 192.168.100.10 net nm 255.255.0.0 net port 5678 net dhcp off		
Returns	None. Check error code.		

NET ip arg1	Network ip address set (COMMAND)
Description	Sets the network ip address to arg1 (xxx.yyy.zzz.aaa)
Returns	None. Check error code.

NET gw arg1	Network gateway address set (COMMAND)
Description	Sets the gateway ip address to arg1 (xxx.yyy.zzz.aaa)
Returns	None. Check error code.

NET nm arg1	Network socket port address set (COMMAND)
Description	Sets the network socket address to arg1
Returns	None. Check error code.

NET port arg1	Network netmask set (COMMAND)
Description	Sets the network netmask to arg1 (xxx.yyy.zzz.aaa)
Returns	None. Check error code.

NET ip arg1	Network ip address set (COMMAND)
Description	Sets the network ip address to arg1 (xxx.yyy.zzz.aaa)
Returns	None. Check error code.

NET dhcp on off	Network dhcp enable set (COMMAND)
Description	Sets the DHCP enable for dynamic IP address (on) or static IP address (off).
Returns	None. Check error code.

NET ad on off	Network autodrop socket connections (COMMAND)
Description	Sets the network autodrop old socket connections to (on) or (off).
Returns	None. Check error code.

NET hostname arg1	Network set new hostname (COMMAND)
Description	Sets the network hostname to arg1.
Returns	None. Check error code.

NET?	Network (QUERY)
Description	The net? query retrieves the values for the currently set network addresses. Note: if no network cable is connected, the IP address returned is invalid (e.g., 0.0.0.0).
Returns	IP=192.168.100.8,NM=255.255.255.0,GW=192.168.100.1, PORT=1234,DHCP=OFF,AD=ON

NET? hostname	Network query hostname (QUERY)
Description	Returns the hostname network address.
Returns	COLBY_YYMMNNNN

NETM?	Network MAC-ID query (QUERY)
Description	The NETM? query returns the network MAC-ID address.
Returns	MAC_ID=0000-0000-0000

6.5 Common Commands

*CAL?	Calibrate Self-Test and Return Status
*CLS	Clears the instrument settings
*IDN?	Identification String (model and serial number)
*RST	Reset instrument
*TST?	Self-Test Trombone and Return Status
*OPC	Set Operation Complete Bit
*OPC?	Query the Operation Complete Bit

*CAL?	Calibration Self-Test Check? (QUERY)	
Description	Performs a calibration self-test check on the electromechanical trombone and returns status	
Returns	0	Calibration self-test passed.
	1	Calibration self-test failed. Service Required.

*CLS	Clear Status (QUERY)	
Description	Clears the instrument and resets any pending errors codes.	
Returns	None	

*IDN?	Instrument Identification Information (QUERY)	
Description	Returns the Instrument identification information.	
Returns	Colby Instruments,XT-100-625P,11111234,V1.00	

*RST	Reset instrument (QUERY)	
Description	Performs an instrument device reset to its initial power-on state. Delay is set to zero delay setting in all channels.	
	Network IP addresses (if previously changed) will take effect	
Returns	None	

*TST?	Calibration Self-Test Check (QUERY)	
Description	Performs an internal self-test by moving the electromechanical trombones to the maximum range limit, testing the optical sensor detection, returning to zero delay position, and re-initializing all internal variables.	
Returns	0	Internal self-test passed.
	1	Internal self-test failed.

*OPC	Operation Complete Status Bit Set (COMMAND)
Description	Sets the Operation Complete Status bit when all pending device operations have finished. This is the default behavior for all command operations. NOTE: The XT-100 blocks (i.e., does not return if queried using *OPC?) until all operations have completed. Use this query and return value to synchronize with automation application.
Returns	None

*OPC?	Operation Complete? (QUERY)				
Description	Returns the status of the Operation Complete Status bit. For all delay setting commands, the Operation Complete Status bit is set after the operation has completed (trombone motor movement has completed). *OPC? query should be used to synchronize setting the delay and waiting until the operation has completed.				
Returns	<table border="1"> <tbody> <tr> <td>0</td> <td>operation has not started yet</td> </tr> <tr> <td>1</td> <td>previous operation has completed</td> </tr> </tbody> </table>	0	operation has not started yet	1	previous operation has completed
0	operation has not started yet				
1	previous operation has completed				

6.6 Relay commands for Models XT-100-001N thru XT-100-100N

Relay Commands for Models XT-100-001N thru XT-100-100N	
REL arg1 [on off]	Relay command set
REL?	Relay query
RELC arg1	Relay exercise cycles

REL arg1 on off	Relay (COMMAND)	
Description	Turns on or off the specified relay number arg1. The value 0 selects ALL relays.	
Example	rel 1 on	turn on relay # 1
	rel 1 off	turn off all relays

REL?	Relay (QUERY)
Description	Returns the current state of relays numbered left (#16) to right (#1)
Example	rel?
Returns	0000000000000101

RELC arg1	Exercise Relay Cycles (COMMAND)
Description	Exercise the relays by cycling the relays (OFF-ON-OFF) for the arg1 specified # of cycles in the range (1 to 100).
Example	relc 50
Returns	None. Check error code.

Chapter 7.0

Instrument Backpanel

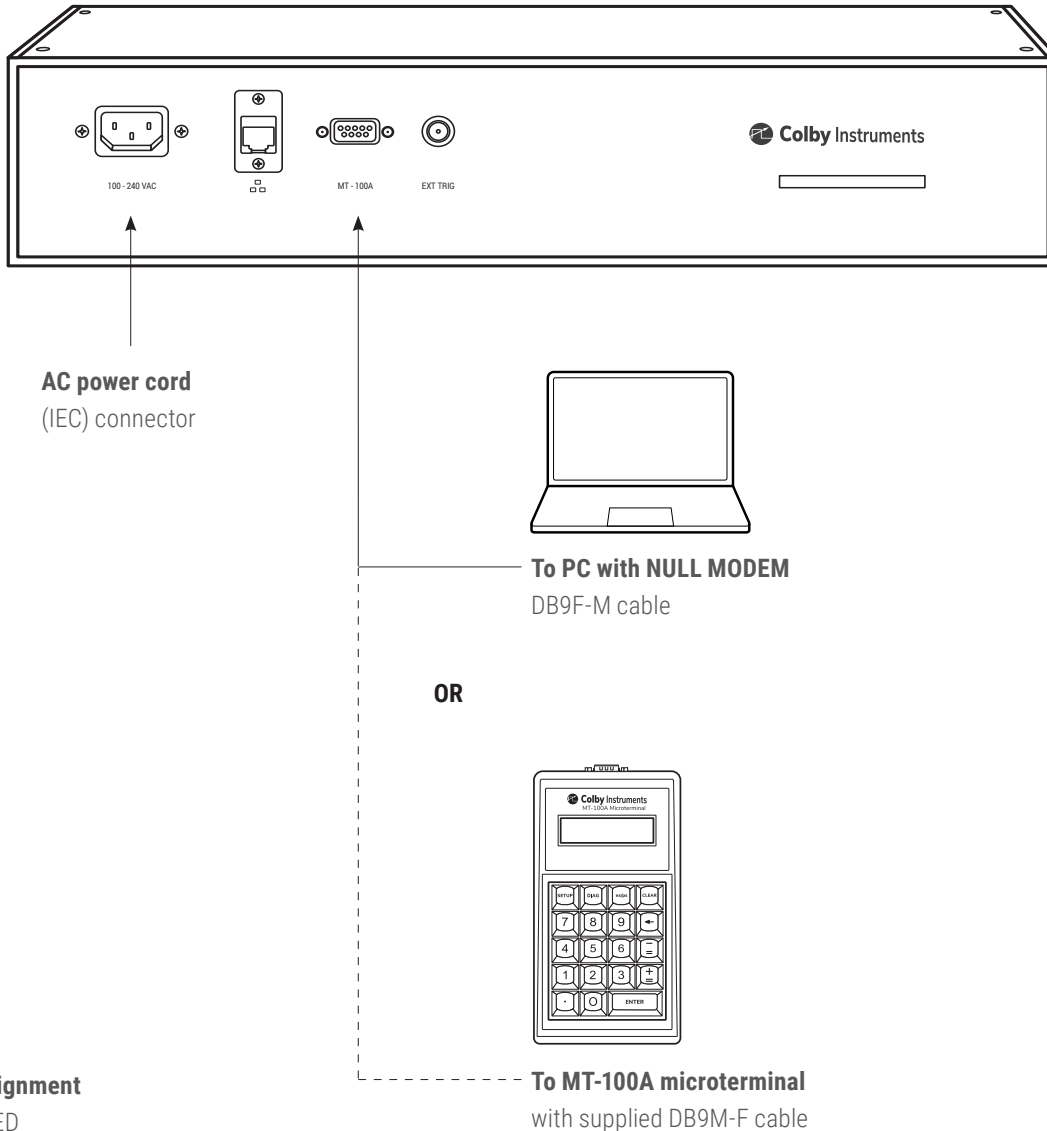

DB-9 Pin Assignment

- PIN 1 UNUSED
- PIN 2 RXD TO X SERIES INSTRUMENT
- PIN 3 TXD FROM X SERIES INSTRUMENT
- PIN 4 UNUSED
- PIN 5 GND
- PIN 6 UNUSED
- PIN 7 UNUSED
- PIN 8 UNUSED
- PIN 9 +5V (FOR MT-100A)*

* DO NOT USE WHEN CONNECTING WITH PC VIA NULL MODEM CABLE

**15375 SE 30th Place, Suite 320
Bellevue, Washington 98007
(425) 452-8889
colbyinstruments.com**
